

Agilent Technologies E444xAU Option H26

Installation Guide

Agilent Technologies E444xAU Option H26

Installation Guide

This manual applies to the following instruments:

E4440A, E4443A, and E4445A



Agilent Technologies

Manufacturing Part Number: E4440-90582

**Printed in USA
October 2004**

© Copyright 2004 Agilent Technologies, Inc. All rights reserved.

Warranty Statement

THE MATERIAL CONTAINED IN THIS DOCUMENT IS PROVIDED “AS IS,” AND IS SUBJECT TO BEING CHANGED, WITHOUT NOTICE, IN FUTURE EDITIONS. FURTHER, TO THE MAXIMUM EXTENT PERMITTED BY APPLICABLE LAW, AGILENT DISCLAIMS ALL WARRANTIES, EITHER EXPRESS OR IMPLIED WITH REGARD TO THIS MANUAL AND ANY INFORMATION CONTAINED HEREIN, INCLUDING BUT NOT LIMITED TO THE IMPLIED WARRANTIES OF MERCHANTABILITY AND FITNESS FOR A PARTICULAR PURPOSE. AGILENT SHALL NOT BE LIABLE FOR ERRORS OR FOR INCIDENTAL OR CONSEQUENTIAL DAMAGES IN CONNECTION WITH THE FURNISHING, USE, OR PERFORMANCE OF THIS DOCUMENT OR ANY INFORMATION CONTAINED HEREIN. SHOULD AGILENT AND THE USER HAVE A SEPARATE WRITTEN AGREEMENT WITH WARRANTY TERMS COVERING THE MATERIAL IN THIS DOCUMENT THAT CONFLICT WITH THESE TERMS, THE WARRANTY TERMS IN THE SEPARATE AGREEMENT WILL CONTROL.

DFARS/Restricted Rights Notice

If software is for use in the performance of a U.S. Government prime contract or subcontract, Software is delivered and licensed as “Commercial computer software” as defined in DFAR 252.227-7014 (June 1995), or as a “commercial item” as defined in FAR 2.101(a) or as “Restricted computer software” as defined in FAR 52.227-19 (June 1987) or any equivalent agency regulation or contract clause. Use, duplication or disclosure of Software is subject to Agilent Technologies’ standard commercial license terms, and non-DOD Departments and Agencies of the U.S. Government will receive no greater than Restricted Rights as defined in FAR 52.227-19(c)(1-2) (June 1987). U.S. Government users will receive no greater than Limited Rights as defined in FAR 52.227-14 (June 1987) or DFAR 252.227-7015 (b)(2) (November 1995), as applicable in any technical data.

Safety Notes

The following safety notes are used throughout this document. Familiarize yourself with each of these notes and its meaning before performing any of the procedures in this document.

WARNING	Warning denotes a hazard. It calls attention to a procedure which, if not correctly performed or adhered to, could result in injury or loss of life. Do not proceed beyond a warning note until the indicated conditions are fully understood and met.
----------------	---

CAUTION	Caution denotes a hazard. It calls attention to a procedure that, if not correctly performed or adhered to, could result in damage to or destruction of the instrument. Do not proceed beyond a caution sign until the indicated conditions are fully understood and met.
----------------	---

Definitions

- *Specifications* describe the performance of parameters covered by the product warranty (temperature - 0 to 55 °C, unless otherwise noted.)
- *Typical* describes additional product performance information that is not covered by the product warranty. It is performance beyond specification that 80% of the units exhibit with a 95% confidence level over the temperature range 20 to 30 °C. Typical performance does not include measurement uncertainty.
- *Nominal* values indicate expected performance, or describe product performance that is useful in the application of the product, but is not covered by the product warranty.

Contents

1 Overview	
Introduction	1-2
Description	1-3
Checking the Shipment/Parts	1-4
Contacting Agilent	1-5
2 Installation	
Removal of Assemblies	2-2
Installation	2-3
3 Amplitude Correction	
Option H26 Corrections Application	3-2
Requirements for using the Software Application	3-2
PC Requirements	3-2
Equipment Required	3-2
Connections	3-2
Installing and Starting the Application	3-3
Configuring I/O Interfaces	3-4
Connecting the Spectrum Analyzer and Signal Generator	3-5
Setting the Start and Stop Frequencies	3-7
Saving the Data to Disk	3-9

1 Overview

Introduction

This chapter guides you through the steps necessary to insure you have received your full order. The steps are:

- “Description” on page 1-3.
- “Checking the Shipment/Parts” on page 1-4.
- “Contacting Agilent” on page 1-5.

Description

The E444xAU H26 is a retrofit kit providing parts to install the high band preamp. The E444xAU H26 consists of the parts listed in [“Checking the Shipment/Parts” on page 1-4](#).

Figure 1-1 Block Diagram for E4440A, E4443A and E4445A H26

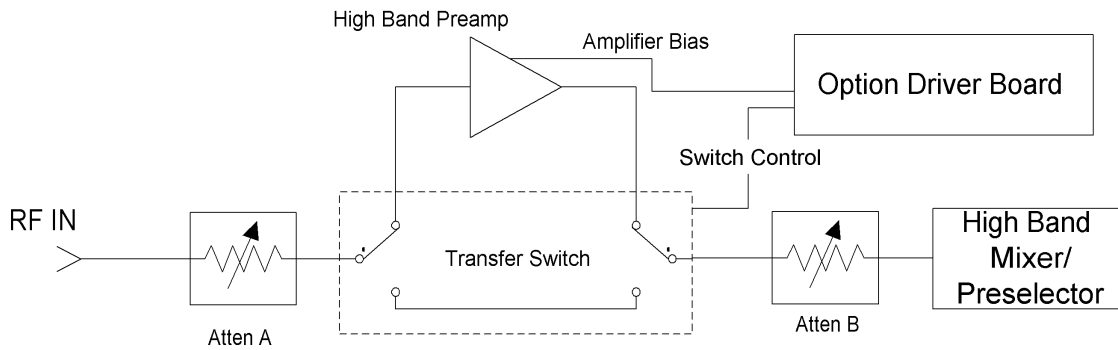

Checking the Shipment/Parts

Checking the Shipment/Parts

Verify the items received in [Table 1-1](#) to make sure that you have received a complete shipment. If there are any signs of damage that may have occurred during shipment, or any accessories appear to be damaged or missing, call your nearest Agilent Technologies sales or service office. Refer to [“Contacting Agilent” on page 1-5](#).

Table 1-1 E4440AU Option H26 Accessories Supplied

Description	Agilent Part Number	Quantity
Screw, M3 x 0.5, 8 mm long	0515-0372	4
Screw, M3 x 0.5, 20 mm long	0515-1410	2
Screw, 2-56 x .312 in long, Pozi	0520-0129	4
Amplifier 3 GHz to 26.5 GHz	0955-1663	1
Washer	2190-0112	4
Entitlement Certificate	5964-5141	1
RF switch	N1811TL-CFG002 ¹	1
H26 amplitude correction disk	E4407-60016	1
Shield, Front Panel Assy	E4440-00050	1
Bracket	E4440-00051	1
E444xAU H26 Install CD-ROM	E4440-10026	1
Cable Assembly, Switch In	E4440-20302	1
Cable assembly, Amp Out	E4440-20303	1
Cable Assembly, Amp In	E4440-20304	1
Cable assembly, Switch Out	E4440-20305	1
Board assy, PSA H26	E4440-60358	1
Cable assembly, ribbon	E4440-60427	1
E444xA H26 User Guide	E4440-90560	1
E444xAU H26 Installation Note	E4440-90582	1
Cable assembly, harness	E4446-60067	1

1. CFG002 corresponds to Options 124, 026, 201, 302 and 403.

Contacting Agilent

By internet, phone, or fax, get assistance with all your test and measurement needs.

Online assistance: www.agilent.com/find/assist			
Americas			
Brazil (tel) (+55) 11 4197 3600 (fax) (+55) 11 4197 3800	Canada (tel) 877 894 4414 (fax) (+1) 905 282-6495	Mexico (tel) (+52) 55 5081 9469 (alt) 01800 5064 800 (fax) (+52) 55 5081 9467	United States (tel) 800 829 4444 (alt) (+1) 303 662 3998 (fax) 800 829 4433
Asia Pacific and Japan			
Australia (tel) 1800 629 485 (alt) 1800 143 243 (fax) 1800 142 134	China (tel) 800 810 0189 (alt) (+86) 10800 650 0021 (fax) 800 820 2816	Hong Kong (tel) 800 930 871 (alt) (+852) 3197 7889 (fax) (+852) 2 506 9233	India (tel) 1600 112 929 (fax) 000800 650 1101
Japan (tel) 0120 421 345 (alt) (+81) 426 56 7832 (fax) 0120 421 678	Malaysia (tel) 1800 888 848 (alt) 1800 828 848 (fax) 1800 801 664	Singapore (tel) 1800 375 8100 (alt) (+65) 6 375 8100 (fax) (+65) 6836 0252	South Korea (tel) 080 769 0800 (alt) (+82) 2 2004 5004 (fax) (+82) 2 2004 5115
Taiwan (tel) 0800 047 866 (alt) 00801 651 317 (fax) 0800 286 331	Thailand (tel) 1800 226 008 (alt) (+66) 2 268 1345 (fax) (+66) 2 661 3714		
Europe			
Austria (tel) 0820 87 44 11* (fax) 0820 87 44 22	Belgium (tel) (+32) (0)2 404 9340 (alt) (+32) (0)2 404 9000 (fax) (+32) (0)2 404 9395	Denmark (tel) (+45) 7013 1515 (alt) (+45) 7013 7313 (fax) (+45) 7013 1555	Finland (tel) (+358) 10 855 2100 (fax) (+358) 10 855 2923
France (tel) 0825 010 700* (alt) (+33) (0)1 6453 5623 (fax) 0825 010 701*	Germany (tel) 01805 24 6333* (alt) 01805 24 6330* (fax) 01805 24 6336*	Ireland (tel) (+353) (0)1 890 924 204 (alt) (+353) (0)1 890 924 206 (fax) (+353) (0)1 890 924 024	Israel (tel) (+972) 3 9288 500 (fax) (+972) 3 9288 501
Italy (tel) (+39) (0)2 9260 8484 (fax) (+39) (0)2 9544 1175	Luxemburg (tel) (+32) (0)2 404 9340 (alt) (+32) (0)2 404 9000 (fax) (+32) (0)2 404 9395	Netherlands (tel) (+31) (0)20 547 2111 (alt) (+31) (0)20 547 2000 (fax) (+31) (0)20 547 2190	Russia (tel) (+7) 095 797 3963 (alt) (+7) 095 797 3900 (fax) (+7) 095 797 3901
Spain (tel) (+34) 91 631 3300 (alt) (+34) 91 631 3000 (fax) (+34) 91 631 3301	Sweden (tel) 0200 88 22 55* (alt) (+46) (0)8 5064 8686 (fax) 020 120 2266*	Switzerland (French) (tel) 0800 80 5353 opt. 2* (alt) (+33) (0)1 6453 5623 (fax) (+41) (0)22 567 5313	Switzerland (German) (tel) 0800 80 5353 opt. 1* (alt) (+49) (0)7031 464 6333 (fax) (+41) (0)1 272 7373
Switzerland (Italian) (tel) 0800 80 5353 opt. 3* (alt) (+39) (0)2 9260 8484 (fax) (+41) (0)22 567 5314	United Kingdom (tel) (+44) (0)7004 666666 (alt) (+44) (0)7004 123123 (fax) (+44) (0)7004 444555		
(tel) = primary telephone number; (alt) = alternate telephone number; (fax) = FAX number; * = in country number			

2 Installation

Removal of Assemblies

Follow the steps as outlined in the Agilent PSA Spectrum Analyzer Service Guide:

1. Instrument Outer Case
2. Chassis Cover
3. Front Frame Assembly. Replace the front frame shield on the instrument with the new shield (E4440-00050) supplied in the kit, if necessary. The new shield will have four standoffs for attaching the bracket plate (E4440-00051).

CAUTION Use ESD precautions when performing these installation procedures

Installation

1. Install the Option Driver board (E4440-60358). The Option Driver board uses the half slot (slot 0) next to the power supply. Refer to [Figure 2-1](#).

Figure 2-1 **Installing the Option Driver board**

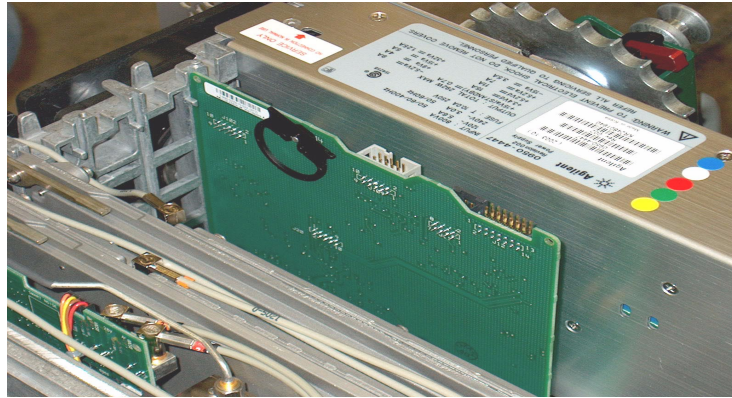

2. Trim all 8 leads on the amplifier (0955-1663) to 1 cm (0.4 in). [Figure 2-2](#) shows the first lead trimmed to length.

Figure 2-2 **Trimming the Leads on the Amplifier**

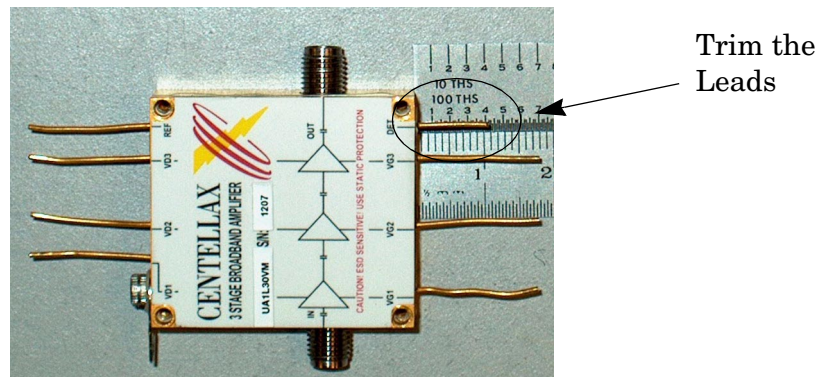

3. Install the amplifier cable assembly (E4446-60067) onto the amplifier (0955-1663). Use caution when pressing the wire connectors onto the pins of the amplifier. They are fragile and can be easily bent or broken. Refer to [Figure 2-3](#).
4. Solder the black wire to the ground pin on the amplifier. Refer to [Figure 2-3](#).

Figure 2-3. Attaching the Cable Assembly to the Amplifier

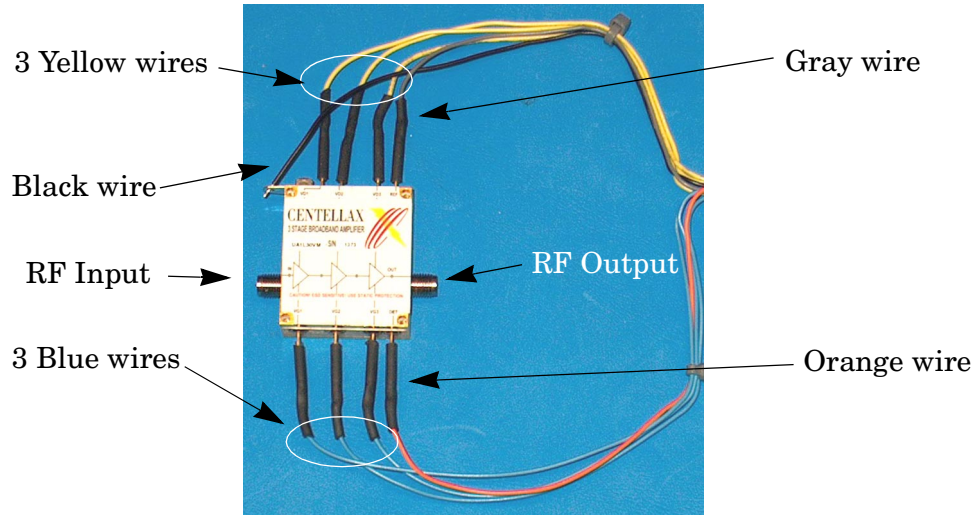

5. Attach the amplifier (0955-1663) to the bracket plate (E4440-00051) using 4 washers (2190-0112) and 4 screws (0520-0129). The amplifier is positioned such that the output connector is toward the edge of the bracket. Torque to 3 in-lb. Refer to [Figure 2-4](#).

Figure 2-4 Installing the Amplifier

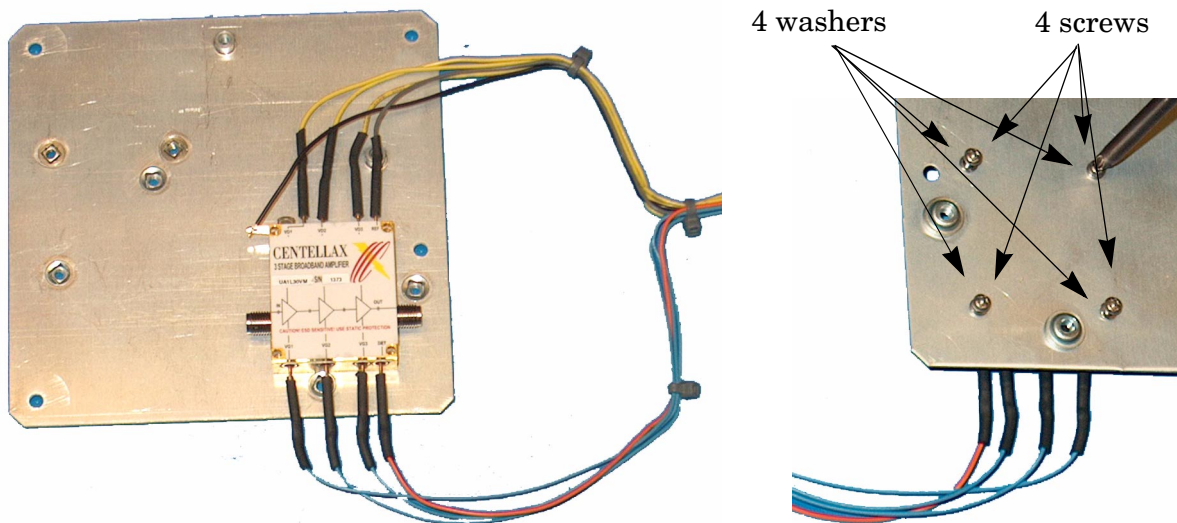

- Attach the RF switch (N1811TL-CFG002) to the bracket plate (E4440-00051) using 2 screws (0515-1410). Torque to 9 in-lb. Refer to [Figure 2-5](#).

Figure 2-5 Attaching RF Switch to Bracket

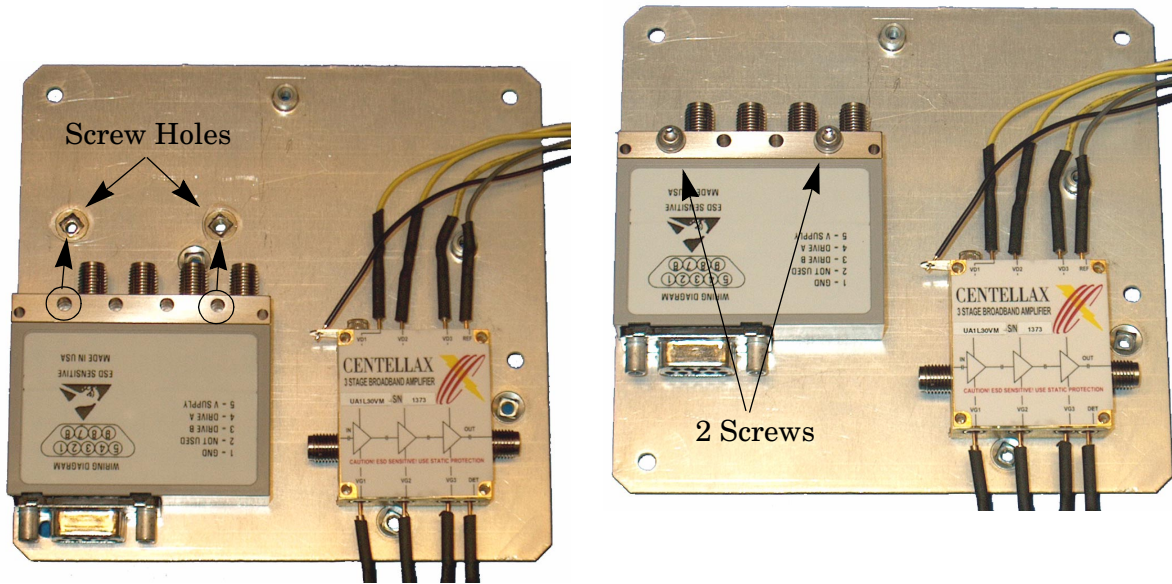

- Install the assembled bracket on the front frame using 4 screws (0515-0372). Torque to 9 in-lbs. Refer to [Figure 2-6](#).

Figure 2-6 Installing the Bracket to the Front Frame

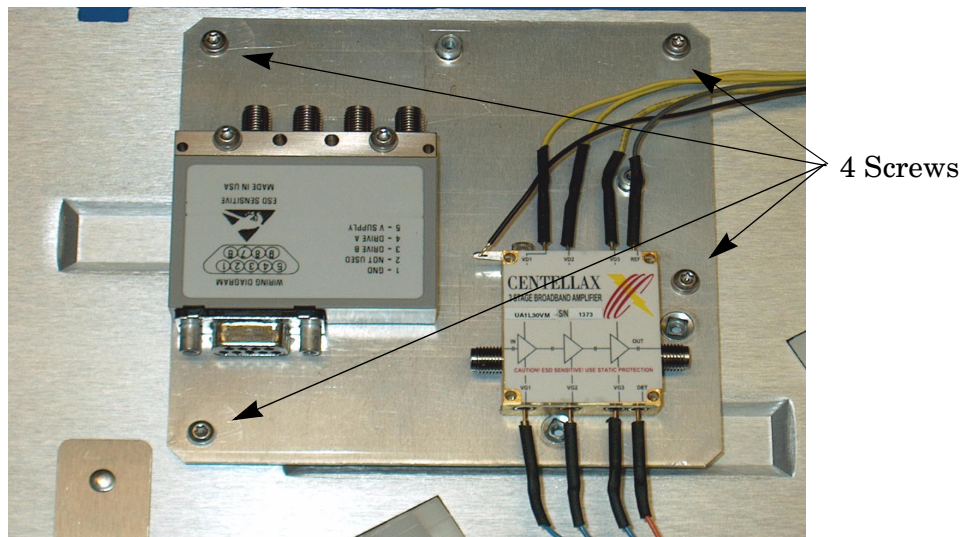

- Attach the cable (E4440-20304) from the amplifier “Amp In” connector to the switch “Port 1.” Torque to 10 in-lbs. Refer to [Figure 2-7](#).

Figure 2-7 Attaching E4440-20304 cable

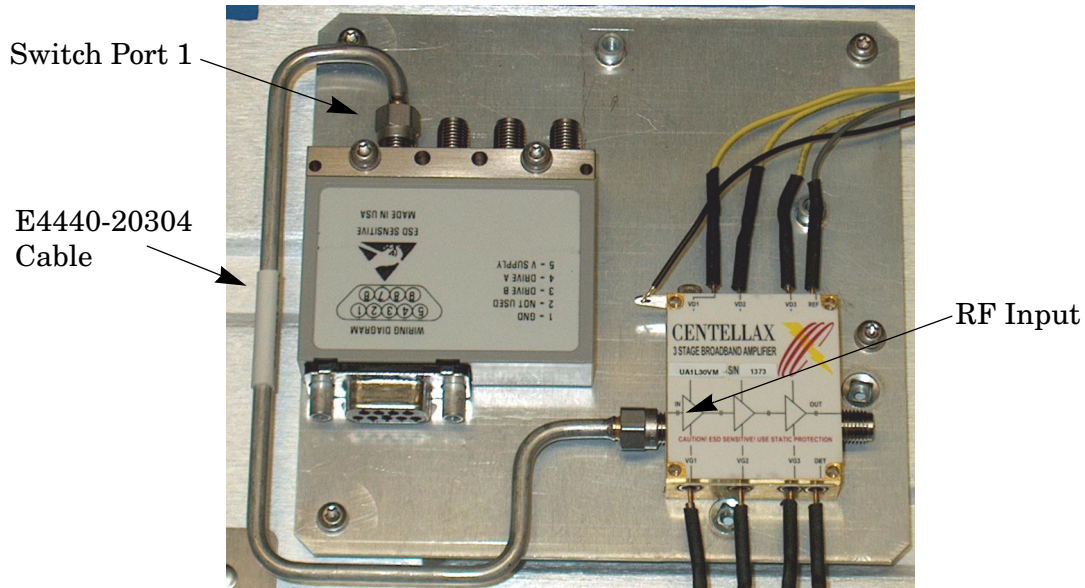

- Attach the cable (E4440-20303) from the amplifier “Amp Out” connector to the switch “Port 4.” Torque to 10 in-lbs. Refer to [Figure 2-8](#). Insure that the cable maintains a right-angle when installed. If the cable is installed backwards, the right angle bend in the cable will not be maintained.

Figure 2-8 Attaching the E4440-20303 Cable

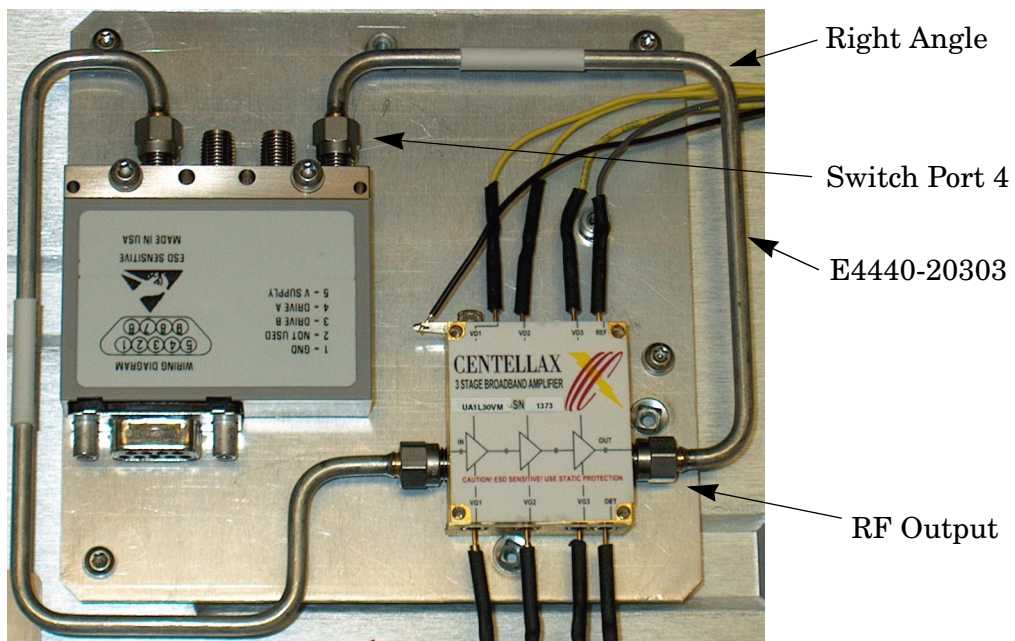

10. Install one end of the ribbon cable (E4440-60427) to the RF switch.
Torque each Load to 10 in-lb. Refer to [Figure 2-9](#).

Figure 2-9 Installing the ribbon cable

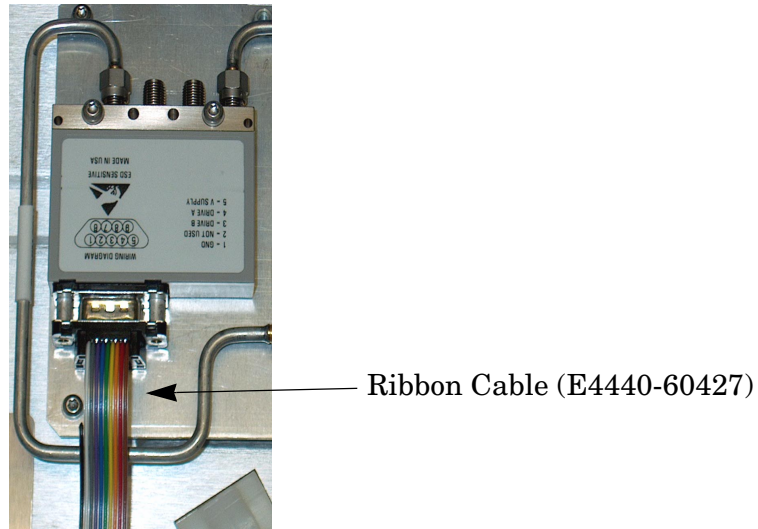

11. Re-install the front frame following the standard procedure.
12. Attach the cable (E4440-20302) from Attenuator A “Out” to the switch “Port 2.”
Torque to 10 in-lb. Refer to [Figure 2-10](#).

Figure 2-10 Attaching the E4440-20302 Cable

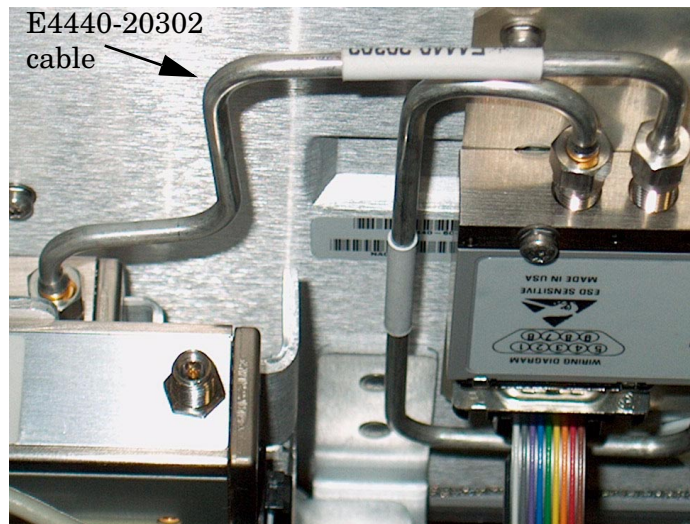

13. Attach the cable (E4440-20305) from Attenuator B “In” to the switch “Port 3.”
Torque to 10 in-lb. Refer to [Figure 2-11](#).

Figure 2-11 Attaching the E4440-20305 Cable

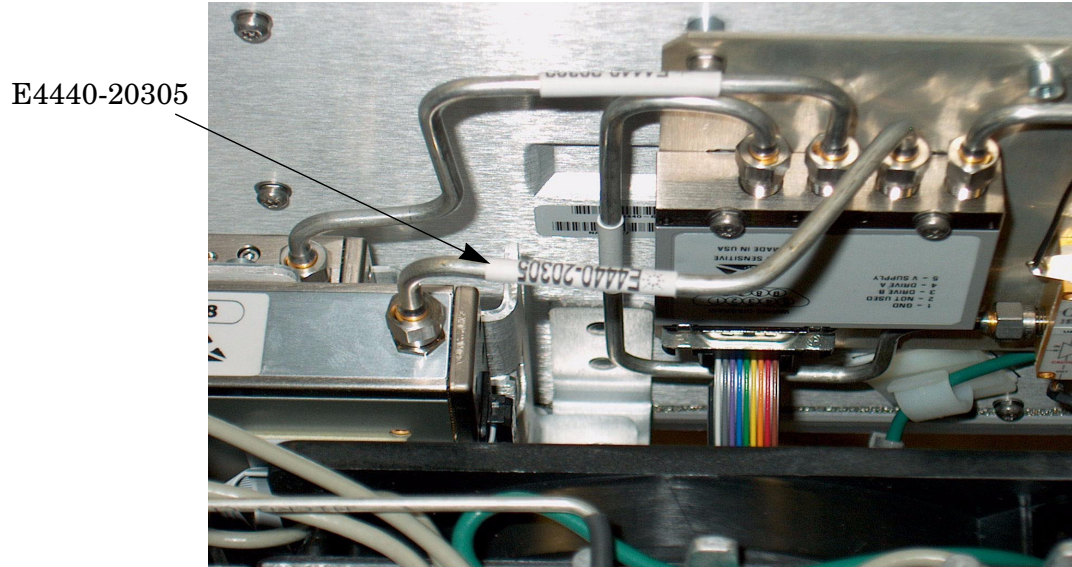

14. Plug the cable assembly (E4446-60067) into J102 of the Option Driver board.
Refer to [Figure 2-12](#).

Figure 2-12 Cable Assembly Connected to J102

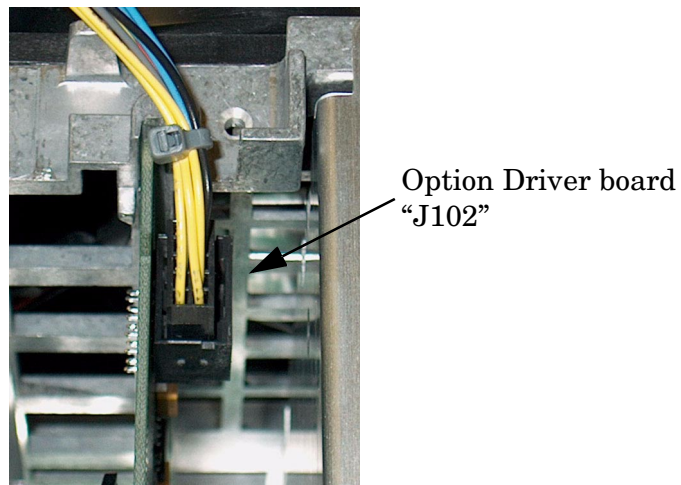

15. Plug the loose end of the ribbon cable (E4440-60427) into J109 of the Option Driver board. Refer to [Figure 2-13](#).

Figure 2-13 Ribbon Cable Connected to J109

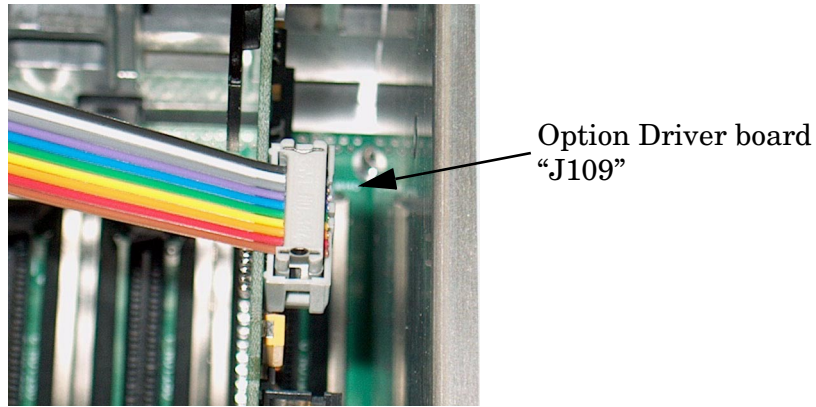

16. Dress the ribbon cable (E4440-60427) as shown in [Figure 2-14](#).

Figure 2-14 Dressing the Ribbon Cable

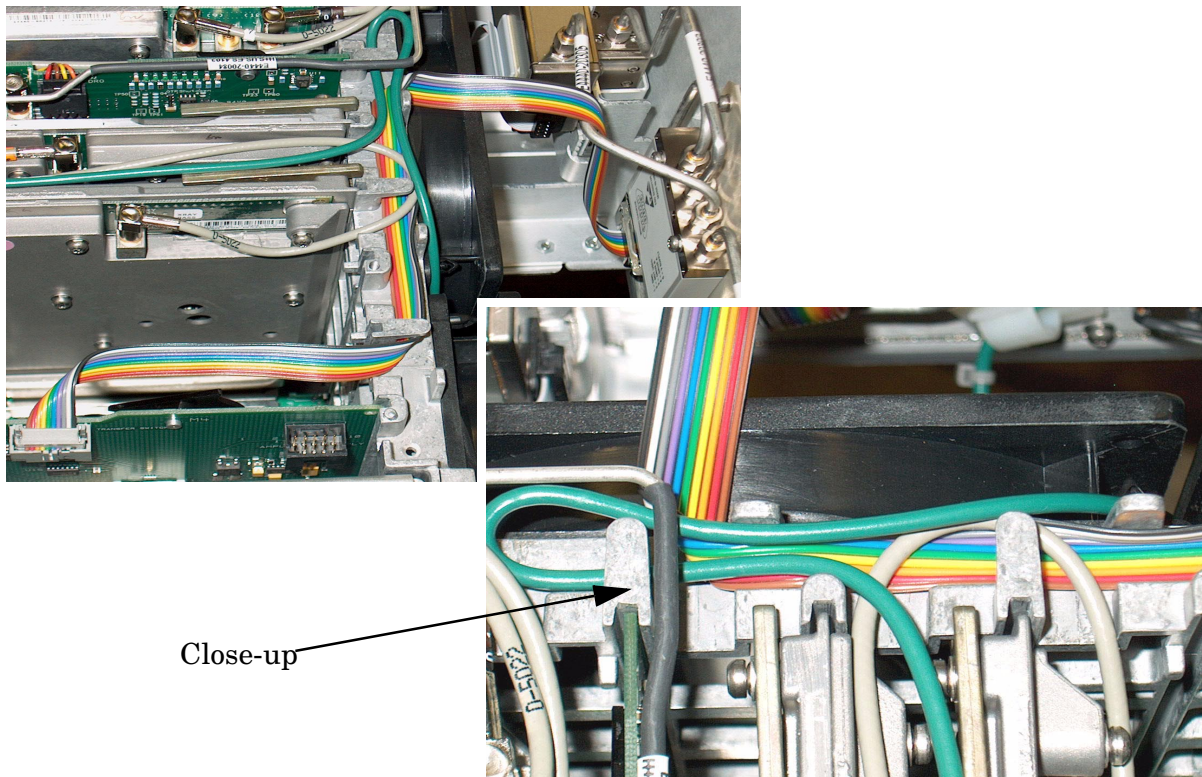

17. Dress the cable assembly (E4446-60067) as shown in [Figure 2-15](#).

Figure 2-15 Dressing the Cable Assembly

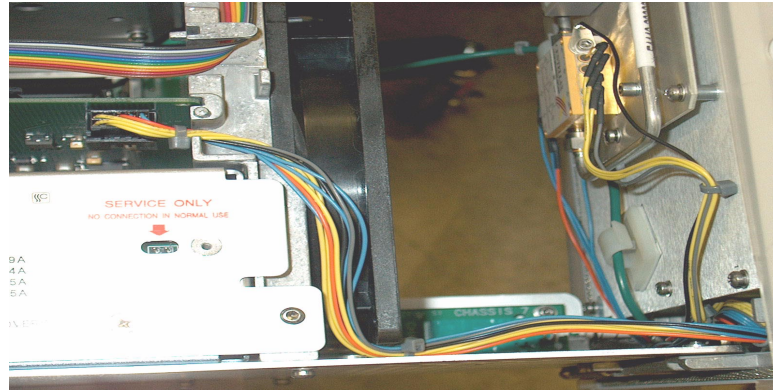

This concludes the “[Installation.](#)” Proceed to [Chapter 3, “Amplitude Correction,”](#) to generate the amplitude correction table for Option H26.

3 Amplitude Correction

Option H26 Corrections Application

The primary purpose of the Amplitude Correction application is to improve amplitude accuracy when using the Option H26 preamp.

The PSA can improve its amplitude accuracy in certain cases by using its internal Amplitude Correction registers. The PSA offers four user-definable Amplitude Correction registers labeled Antenna, Cable, Other and User. The Option H26 application stores its correction data in the register labeled “**OTHER**”.

The application also allows the user to correct the preamp over a subset of its full frequency range. This enables the correction values to be concentrated over a narrower frequency range, which will accurately measure the preamp amplitude flatness. For example; if the frequencies of interest were between 12 and 13 GHz, the correction would be performed only in this range and the correction values applied only in this region.

NOTE The instrument does not automatically enable the above mentioned Amplitude Corrections, they must be enabled by the user where appropriate. Unlike the option 1DS lowband preamp where the lowband preamp flatness is corrected automatically, the Amplitude Correction “**OTHER**” must be turned “ON” when the Preamp is turned “ON” and turned “OFF” when the Preamp is turned “OFF.” Measurement errors will result if this is not done. Refer to the E444xA H26 User’s Guide (E4440-90560) contained on the CD.

Requirements for using the Software Application

PC Requirements

- Computer running Windows 2000 Professional or WindowsXP operating systems
- Microsoft .NET Framework 1.1 (free download from Microsoft’s website or available on the CD)
- Agilent I/O Libraries Version M or later
- GPIB or LAN connection
- CD or DVD drive

Equipment Required

- PSA with Option H26
- Signal Generator (The following models are supported: 83623A/B, 83630A/B, 83640A/B, 83650A/B, E4438C or E8267C/D).
- Cable to connect Generator RF Output to Analyzer RF Input

Connections

- Connect the Signal Generator RF output to the Spectrum Analyzer RF Input
- Connect Generator and Analyzer to PC via GPIB or LAN

Installing and Starting the Application

1. Insert the CD-ROM into your computer.
2. If Autostart does not install the application after a few moments, manually perform the following: **Start > Run > Browse**. Select the drive where the CD is located. Select the file “**H26app.msi**” and click **OK**. The program should now install on your computer.

NOTE The Microsoft .NET Framework must be installed prior to installing the Option H26 application. The Framework is available at Microsoft’s website (also through Windows Update) and is also provided on the CD (locate dotnetfx.exe in the Framework folder).

3. Locate the program “*H26 Amplitude Corrections*” by navigating to the **Start > Programs** window or using the icon located on the desktop.

The start of the program will appear as in [Figure 3-1](#).

Figure 3-1 Starting the H26 Amplitude Corrections Application

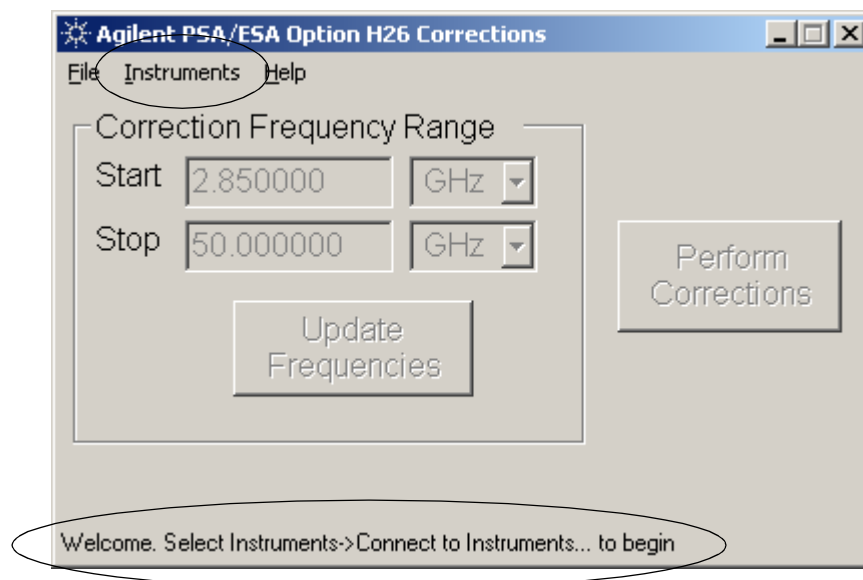

The program startup window contains entry fields for setting the start and stop frequencies, an Update Frequencies button, a Perform Corrections button, menu bar, and a status bar at the bottom of the window. Detailed information will be provided in the following sections.

Configuring I/O Interfaces

Before an instrument can be controlled by software applications on the PC, Agilent I/O Libraries must be configured properly.

1. Run Agilent I/O Config, either from the **Start > Programs** menu or by clicking on the blue “IO” icon in the Windows Taskbar.
2. Select your hardware interface from the Available Interface Type list and enable it for use by clicking the Configure button. See the I/O Libraries documentation for information about configuring specific hardware interfaces.

Figure 3-2 Agilent I/O Config Utility

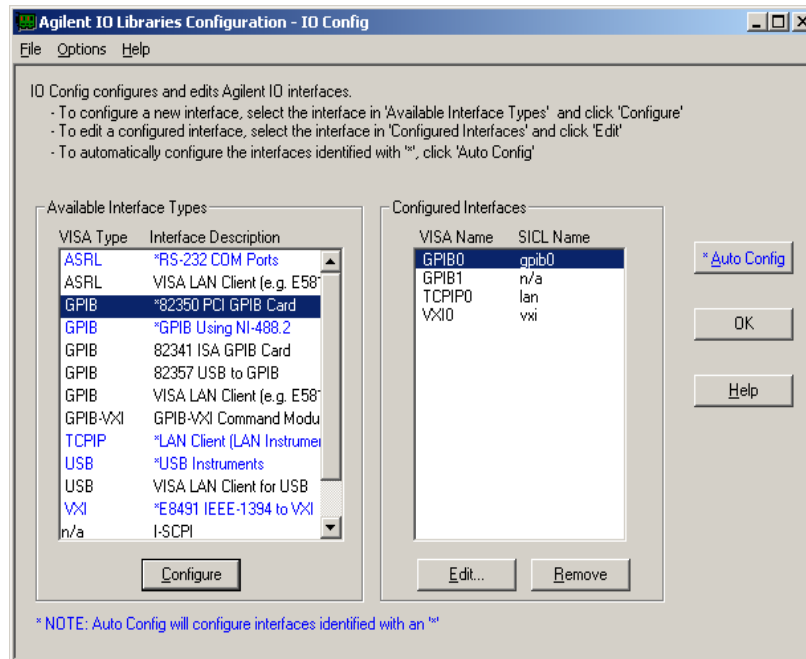

Connecting the Spectrum Analyzer and Signal Generator

The application must connect to the spectrum analyzer and the signal generator in order to function.

1. Select **Instruments > Connect to Instruments** from the drop-down menu. A new window will be displayed as in [Figure 3-3](#). Enter the GPIB or LAN address of your instrument. The actual Interface and Address numbers will depend on what interfaces you configured in I/O Config in [Step 2 on page 3-4](#). For example, if the VISA Name of your GPIB card is “GPIB0”, and your Analyzer is located at address 18, then you would enter “0” for the Interface number and “18” for the Address number.
2. Click **Connect**.

Figure 3-3 **Connect to Instruments**



Once the instrument is connected, [Figure 3-4](#) displays information such as the model number, serial number and firmware revision.

3. Select the Signal Generator tab.
4. Configure your signal generator by entering its Interface and Address information and clicking the Connect button.
5. After instruments are connected, close the Configure Instruments window. You may repeat this process later to connect to other signal analyzers or generators.

Figure 3-4 **Connecting to the Spectrum Analyzer**

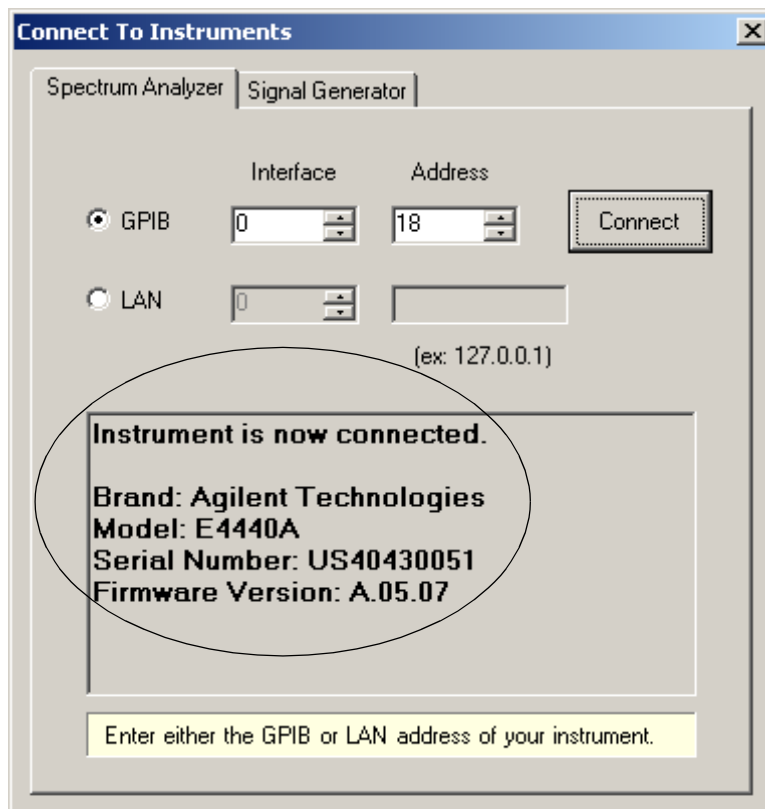

Setting the Start and Stop Frequencies

After connecting the instruments, the Start and Stop frequencies are enabled for updating as shown in [Figure 3-5](#). Although the application begins with default Start and Stop frequencies, the Stop frequency will be updated after connecting the hardware. Its new value will reflect the limits imposed by the currently connected instruments. The Start frequency has a lower limit of 2.85 GHz imposed by the start frequency of the high band preamp.

1. To override the default Start and Stop frequencies, enter the desired values and click **Update Frequencies**.
2. Click **Perform Corrections** to begin the correction routine.

Figure 3-5 Setting the Start and Stop Frequencies

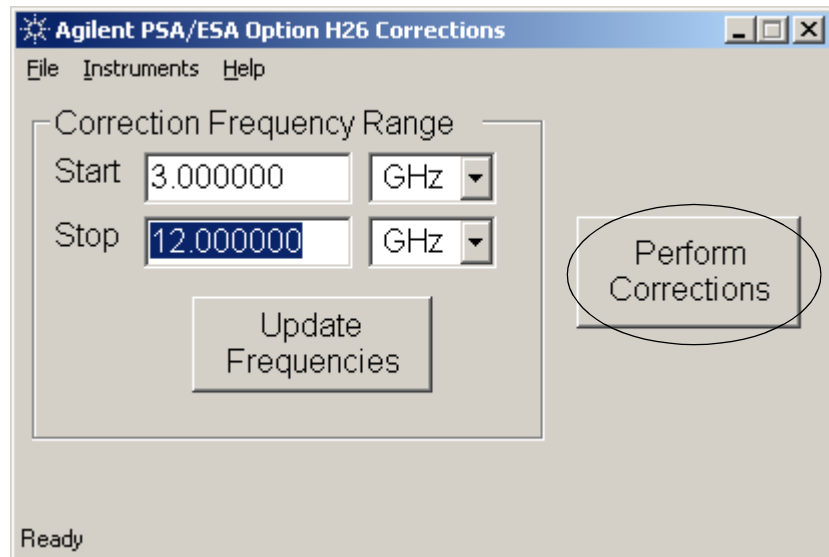
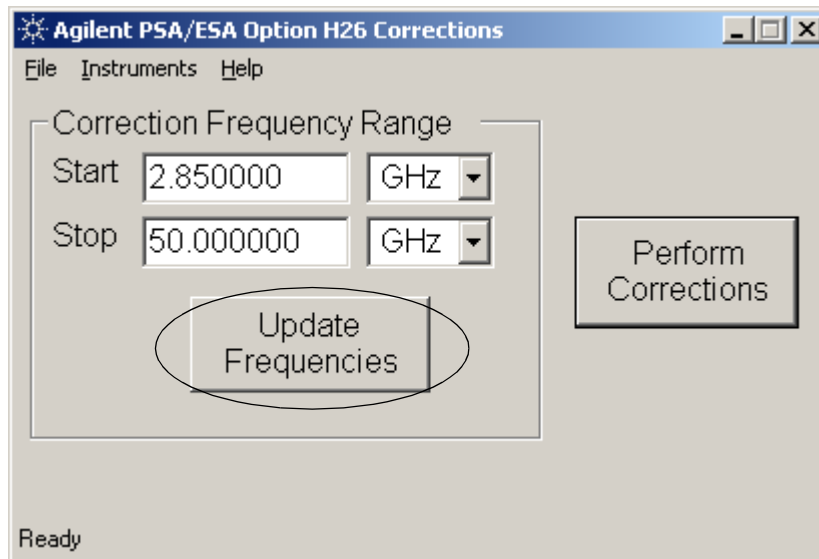

Once running, the application displays the progress of the correction routine as shown in [Figure 3-6](#). This may take several minutes. When the routine has finished, the application displays the “*Correction Routine is Finished*” message in its status bar. The correction data will be automatically stored in the “**OTHER**” register at the end of the correction routine. If for some reason the process needs to be stopped and restarted, click the **Abort** button.

Figure 3-6 Performing the Corrections

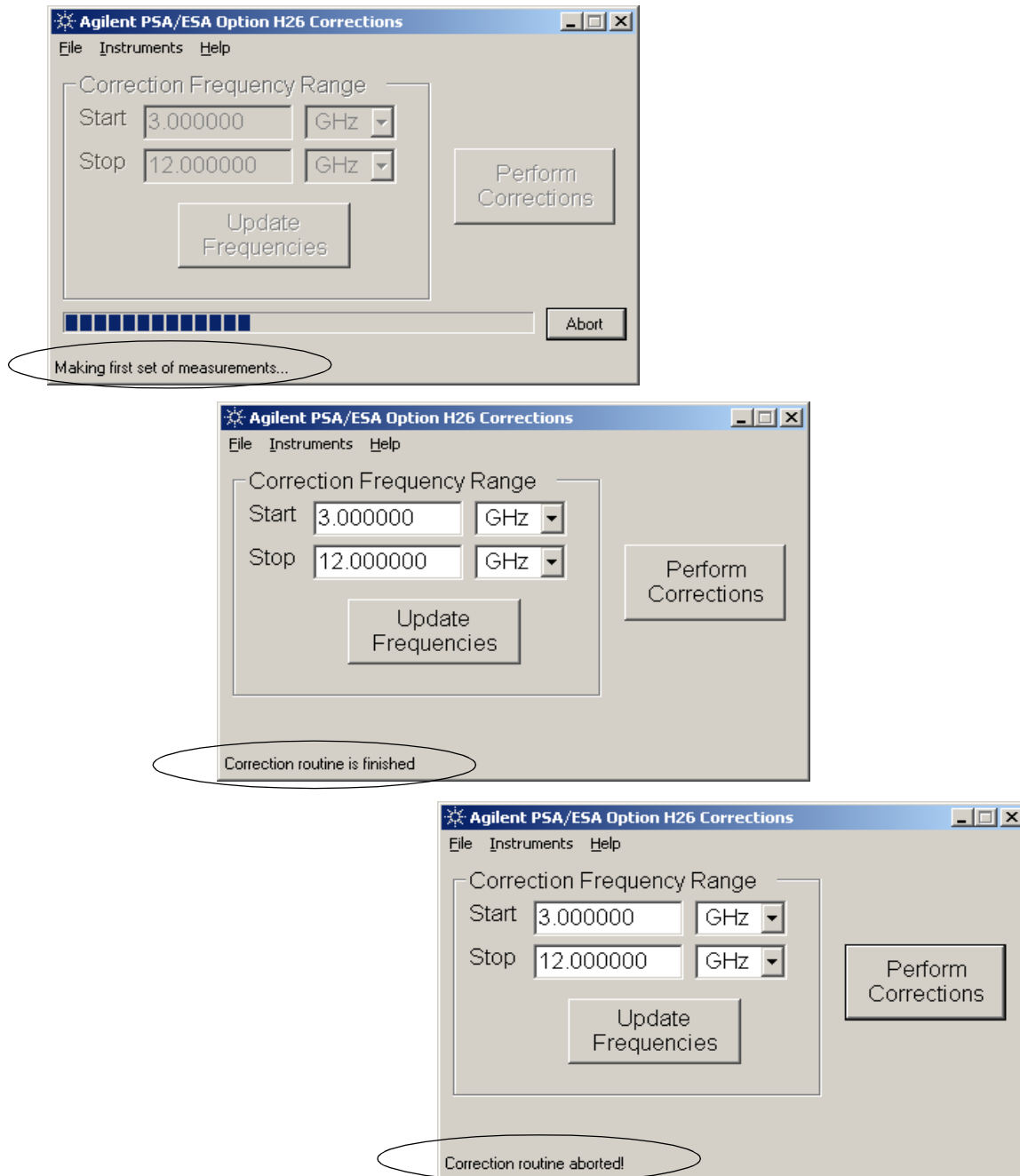

Saving the Data to Disk

The data can be saved to a floppy disk in the PSA as a backup file. This option becomes available after a correction routine is successfully completed.

NOTE Starting a new correction routine prevents the application from saving any previous correction data to disk. Also, if a correction routine is Aborted it is impossible to save data from the last successful routine. It is recommended that correction data be saved to disk before running the routine again.

1. Click **File > Save to Disk**. Insure a floppy disk has been inserted in the PSA.
2. Click **OK**. Once finalized, the message “*Save Complete*” is displayed. A backup copy is stored on the c: drive of the PSA as a safety precaution.

Figure 3-7 Saving the Data to Disk

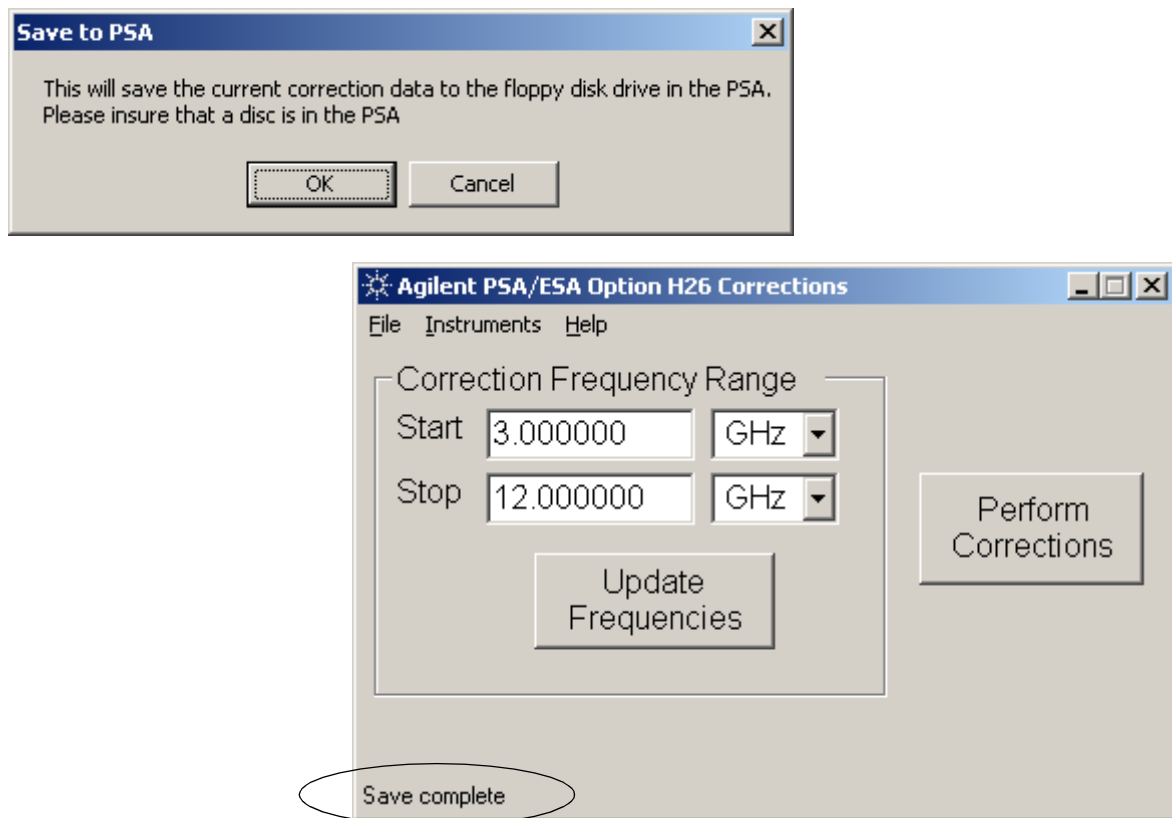

If a failure occurs when saving to disk, the “*Save Failed...*” message is displayed. This may occur for such things as a full disk, or a disk not inserted in the PSA.

Figure 3-8 “Save Failed” Error Message

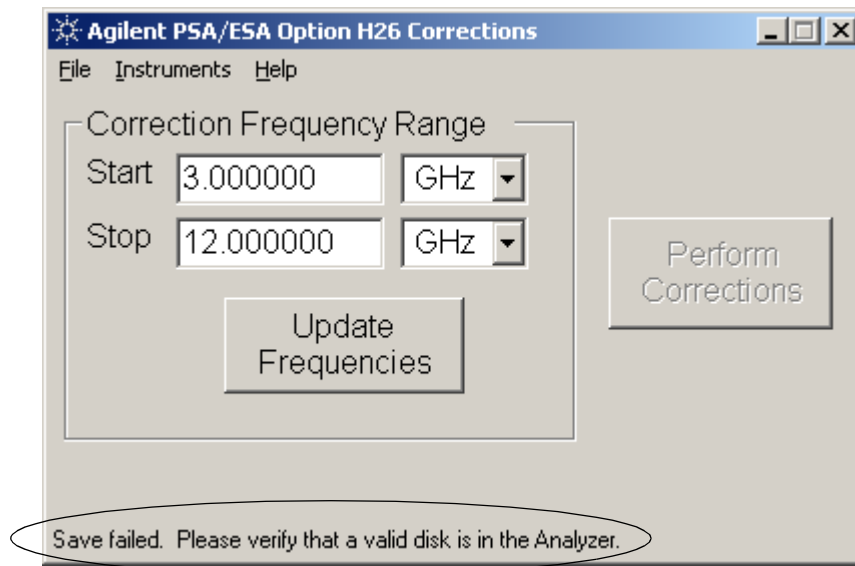

This concludes the “Amplitude Correction.”